

K-STOPPVENTILE IG

Stop valves, ports 2 and 3 with female thread

HANSA FLEX

属性

工作压力	Max. 10 bar
控制压力	1 - 5 bar, depending on operating pressure
介质温度	max. 70 °C
装入位置	Any. Ring pieces can still be rotated 360° after the valve has been tightened
原料	黄铜镀镍
密封材料	Perbunan

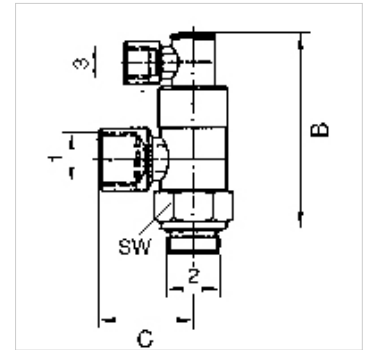

提示

其它数据应客户要求提供。

描述

For high-speed positioning and stop functions as well as emergency switching (e.g. emergency stop). If a control signal is present at port 3, air can flow to and from the cylinder. If no control signal is present, the air flow to and from the cylinder is shut off, causing the cylinder to stop in the required position. Stop valves are screwed directly onto the cylinder instead of the normal pipe connections.

货品

名称	Port 1	Port 2	接口 3	B (mm)	C (mm)
K- 07 15 20 46	G 1/8	G 1/8	G 1/8	52,0	21,0
K- 07 15 20 45	G 1/4	G 1/4	G 1/8	58,0	25,0
K- 07 15 20 47	G 3/8	G 3/8	G 1/8	63,0	31,0
K- 07 15 20 44	G 1/2	G 1/2	G 1/8	72,0	40,0