

K-FI AK KOH METALLBEHAEL SI VARIOBL

Activated carbon filters with metal bowl incl. sight glass

HANSA FLEX

属性

入口压力	Max. 16 bar (polycarbonate bowl), Max. 20 bar (metal bowl)
介质温度	max. 50 °C
环境温度	Max. 50 °C (polycarbonate bowl), Max. 80 °C (metal bowl)
空气质量符合 ISO 85731	Class 1 dirt, class 1 oil
剩余油含量	0,003 mg/m ³
流量值测量	At P1 = 7 bar and pressure drop $\Delta p = 0,1$ bar

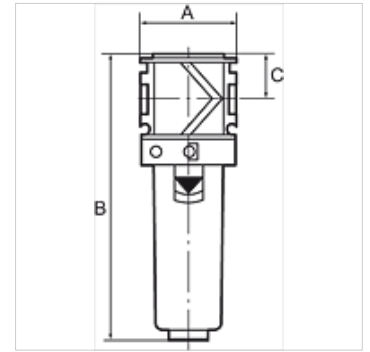

提示

Activated carbon filters are also supplied with protective cage or metal container.
其它数据应客户要求提供。

描述

The activated carbon filter absorbs oil vapour from the compressed air. The entering compressed air needs to be dry and free of contaminants (an upstream microfilter is strongly recommended).

货品

名称	螺纹	流量 (L/min)	A (mm)	B	C (mm)
K- 07 25 23 07	G 1/4	800	48,0	142,0 mm	22,0
K- 07 25 23 08	G 3/8	1000	48,0	142,0 mm	22,0
K- 07 25 23 09	G 1/2	1200	70,0	193,0 mm	26,0
K- 07 25 23 10	G 3/4	1300	70,0	193,0 mm	26,0
K- 07 25 23 11	G 1	1300	124,0	193,0 mm	26,0