

K-RED FLANSCH 80-100 IG INFI

Reducing flange Ø 80 mm/Ø 110 mm with female thread

属性

适用介质	Compressed air, vacuum, inert gases
工作压力	-0,99 bar - 15 bar
温度范围	-20 °C to +80 °C
导环	Technopolymer
壳体	Aluminium, treated surface
内六角螺栓	Galvanised steel
夹紧环	Stainless steel 1.4301
螺母	Aluminium, surface treated
O 形圈	NBR
自锁式螺母	Galvanised steel
防护垫圈	Technopolymer

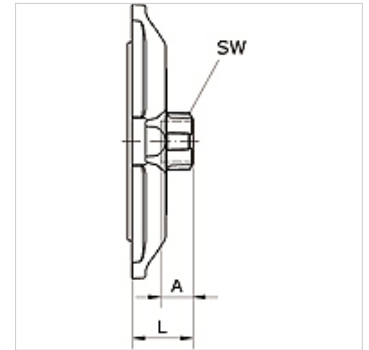

货品

名称	接口	用于管外径-Ø mm	A (mm)	L (mm)	SW (mm)
K- 07 40 55 23	G 3/4	80	14,5	42,0	42
K- 07 40 55 24	G 1	80	17,0	42,0	49
K- 07 40 55 25	G 1 1/2	80	20,0	42,0	66
K- 07 40 55 26	G 2	80	22,0	42,0	80
K- 07 40 54 73	G 3/4	110	14,5	48,0	42
K- 07 40 54 74	G 1	110	17,0	48,0	49
K- 07 40 54 75	G 1 1/2	110	20,0	48,0	66
K- 07 40 54 76	G 2	110	22,0	48,0	80